

Commission Information:
 Initiated by: Planning and Zoning
 Commission
 September 17, 2015
 First on Agenda: postponed from August 20,
 2015
 Action: Approved
 Vote: Unanimously
 Council Information:
 Introduced by: City Manager Wallace
 Introduced: January 12, 2016
 Public Hearing: January 26, 2016
 Action: Adopted
 Vote: Unanimous

Yes:	No:
Best	
LaFrance	
Combs	
DeVries	
Johnson	
Hanson	

CITY OF PALMER, ALASKA

Ordinance No. 16-001

An Ordinance of the Palmer City Council Amending Palmer Municipal Code Chapter 17.08 Definitions to include 17.08.208 Handicapped Accessible Ramps; and amending Chapter 17.60.050 Projections into Required Yards to Add 17.60.050(G)

THE CITY OF PALMER, ALASKA ORDAINS:

Section 1. Classification. This ordinance shall be permanent in nature and shall be incorporated into the Palmer Municipal Code.

Section 2. Severability. If any provision of this ordinance or any application thereof to any person or circumstance is held invalid, the remainder of this ordinance and the application to other persons or circumstances shall not be affected thereby.

Section 3. Chapter 17.08.208 is hereby enacted to read as follows:

17.08.208 Handicapped accessible ramps.

“Handicapped accessible ramps” means a walking surface that is part of a route providing access to a building for persons with limited mobility and providing a reasonable accommodation under the Fair Housing Act and the Americans with Disabilities Act.

Section 4. Chapter 17.60.050(G) is hereby amended to read as follows (new language is underlined):

17.60.050 Projections into required yards.

Projections into required yards of both principal and accessory structures shall be prohibited except as follows:

- A. Paved terraces may project into required front, side or rear yards, provided that no structures placed there violate other requirements of this title;
- B. Unroofed landings and stairs may project into required rear yards only;
- C. Cornices, eaves and similar incidental architectural features may project not more than two feet into any required yard;
- D. An accessory building not exceeding 14 feet in height may be permitted to occupy a rear yard; provided, that no more than one-third of the total area of such rear yard shall be so occupied;
- E. Every building erected after January 17, 1978, shall be located on a lot as defined in PMC 17.08.255;
- F. In residential districts, an enclosed porch or arctic entry, including their roofs, may project into a required front or rear yard not more than five feet if the enclosed porch or arctic entry is no larger than 35 square feet of gross floor area and there is no other practicable location for such an entrance on the structure. This provision is restricted to dwellings constructed before January 1, 1986.
- G. In residential districts, the installation of handicapped accessible ramps with handrails in any required setback.
 - 1. These ramps may be roofed but not fully enclosed; and
 - 2. Shall be constructed in accordance with Section 405 Ramps of International Code Council ICC A117.1-2009.

Section 5. Effective Date. Ordinance No. 16-001 shall take effect upon adoption by the City of Palmer City Council.

Passed and approved this twenty-sixth day of January, 2016.

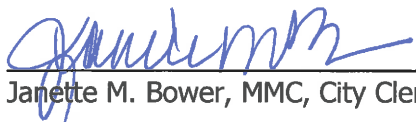

Janette M. Bower, MMC, City Clerk

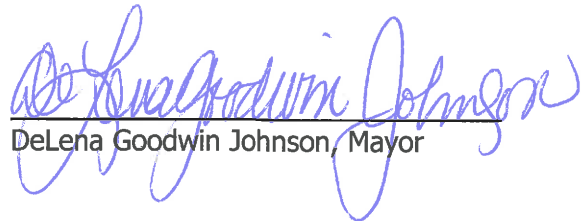

DeLena Goodwin Johnson, Mayor

The Commission discussed if a recommendation should be made to the City Council. Staff was asked to submit information on Title 14, Signs, and put it on the agenda for the next meeting to determine whether it should draft a resolution.

- G. PUBLIC HEARING(s): There were no public hearings.
- H. UNFINISHED BUSINESS: There was no Unfinished Business.
- I. NEW BUSINESS:

1. **IM 15-018**: Consideration of text amendment to PMC 17.60.050, Projections Into Required Yards, to permit ADA accessibility ramps within required setbacks.



Ms. Garley reported that currently there are no exceptions in PMC 17.60.050 to allow for the encroachment of accessibility ramps into required setbacks. A recent request to install an accessibility (handicap) ramp to the front entry of a house which would encroach into the front yard setback has been brought to the City's attention. The draft ordinance for review in the packet would permit accessibility ramps to encroach into any required yard. She asked the Commission to review/revise the draft Ordinance recommending approval and forward to the City Council.

Discussion and questions of staff ensued. David Meneses participated in the discussion and answered commissioner questions. The Commission reviewed the draft Ordinance and suggested minor wording revision.

Commissioner Lucas moved, seconded by **Commissioner Petty**, to recommend approval of PMC 17.60.050(G), Projections into required yards, as modified pursuant to discussion, and forward to the City Council.

VOTE ON MOTION: Carried Unanimously.

2. **IM 15-020**: Shared Use Parking Agreement between Tree of Life Church and Alaska Bible College.

Ms. Garley summarized that The Tree of Life Church intends to remodel the east side of the building currently being used as a church. There is no current parking calculation for the entire use of the Hillstrom Building. Staff has calculated the parking requirement for the Hillstrom Building to be 54 required parking spaces and recommends approval of the use of shared parking with the Alaska Bible College to provide additional parking for the Hillstrom Building located at 268 E. Fireweed Avenue.

Pastor Paul Steiner, Tree of Life Church, spoke in favor of the Parking Agreement and asked the Commission for approval.

Commissioner Petty moved, seconded by **Commissioner Cruthers**, to approve the Parking Agreement between Tree of Life Church and Alaska Bible College.

VOTE ON MOTION: Carried Unanimously.

405 Ramps

405.1 General. Ramps along accessible routes shall comply with Section 405.

EXCEPTION: In assembly areas, aisle ramps adjacent to seating and not serving elements required to be on an accessible route shall not be required to comply with Section 405.

405.2 Slope. Ramp runs shall have a running slope greater than 1:20 and not steeper than 1:12.

EXCEPTION: In existing buildings or facilities, ramps shall be permitted to have slopes steeper than 1:12 complying with Table 405.2 where such slopes are necessary due to space limitations.

405.3 Cross Slope. Cross slope of ramp runs shall not be steeper than 1:48.

405.4 Floor Surfaces. Floor surfaces of ramp runs shall comply with Section 302.

405.5 Clear Width. The clear width of a ramp run shall be 36 inches (915 mm) minimum. Handrails and hand-rail supports that are provided on the ramp run shall not project into the required clear width of the ramp run.

405.6 Rise. The rise for any ramp run shall be 30 inches (760 mm) maximum.

405.7 Landings. Ramps shall have landings at the bottom and top of each ramp run. Landings shall comply with Section 405.7.

405.7.1 Slope. Landings shall have a slope not steeper than 1:48 and shall comply with Section 302.

405.7.2 Width. Clear width of landings shall be at least as wide as the widest ramp run leading to the landing.

405.7.3 Length. Landings shall have a clear length of 60 inches (1525 mm) minimum.

405.7.4 Change in Direction. Ramps that change direction at ramp landings shall be sized to provide a turning space complying with Section 304.3.

405.7.5 Doorways. Where doorways are adjacent to a ramp landing, maneuvering clearances required by Sections 404.2.3 and 404.3.2 shall be permitted to overlap the landing area. Where a door that is subject to locking is located adjacent to a ramp landing, the landing shall be sized to provide a turning space complying with Section 304.3.

405.8 Handrails. Ramp runs with a rise greater than 6 inches (150 mm) shall have handrails complying with Section 505.

TABLE 405.2—ALLOWABLE RAMP DIMENSIONS FOR CONSTRUCTION IN EXISTING SITES, BUILDINGS AND FACILITIES

Slope ¹	Maximum Rise
Steeper than 1:10 but not steeper than 1:8	3 inches (75 mm)
Steeper than 1:12 but not steeper than 1:10	6 inches (150 mm)

¹A slope steeper than 1:8 shall not be permitted.

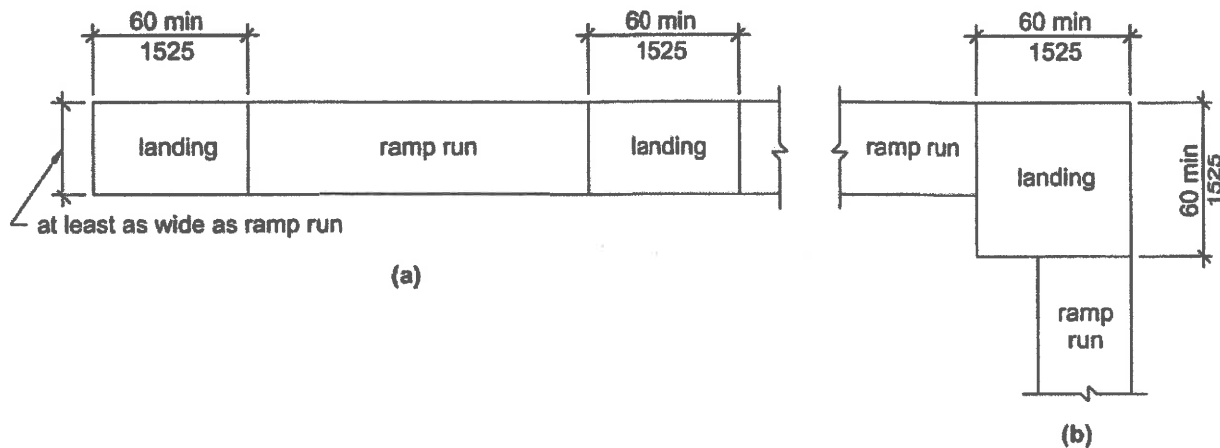

FIG. 405.7 RAMP LANDINGS

405.9 Edge Protection. Edge protection complying with Section 405.9.1 or 405.9.2 shall be provided on each side of ramp runs and at each side of ramp landings.

EXCEPTIONS:

1. Edge protection shall not be required on ramps not required to have handrails and that have flared sides complying with Section 406.3.
2. Edge protection shall not be required on the sides of ramp landings serving an adjoining ramp run or stairway.
3. Edge protection shall not be required on the sides of ramp landings having a vertical drop-off of 1/2 inch (13 mm) maximum within 10 inches (255 mm) horizontally of the minimum landing area specified in Section 405.7.
4. Edge protection shall not be required on the sides of ramped aisles where the ramps provide access to the adjacent seats and aisle access ways.

405.9.1 Extended Floor Surface. The floor surface of the ramp run or ramp landing shall extend 12 inches (305 mm) minimum beyond the inside face of a railing complying with Section 505.

405.9.2 Curb or Barrier. A curb complying with Section 405.9.2.1 or a barrier complying with Section 405.9.2.2 shall be provided.

405.9.2.1 Curb. A curb shall be a minimum of 4 inches (100 mm) in height.

405.9.2.2 Barrier. Barriers shall be constructed so that the barrier prevents the passage of a 4-inch (100 mm) diameter sphere where any portion of the sphere is within 4 inches (100 mm) of the floor.

405.10 Wet Conditions. Landings subject to wet conditions shall be designed to prevent the accumulation of water.

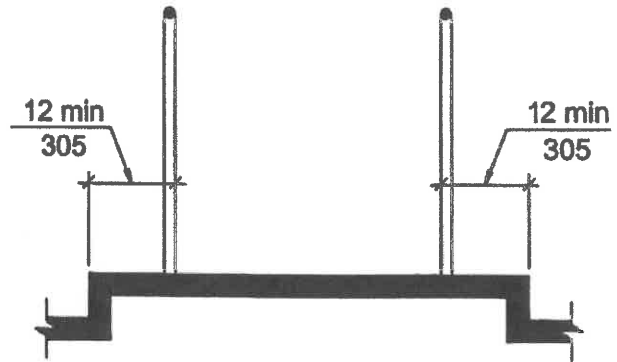

Extended Floor Surface

**FIG. 405.9.1
EXTENDED FLOOR SURFACE**

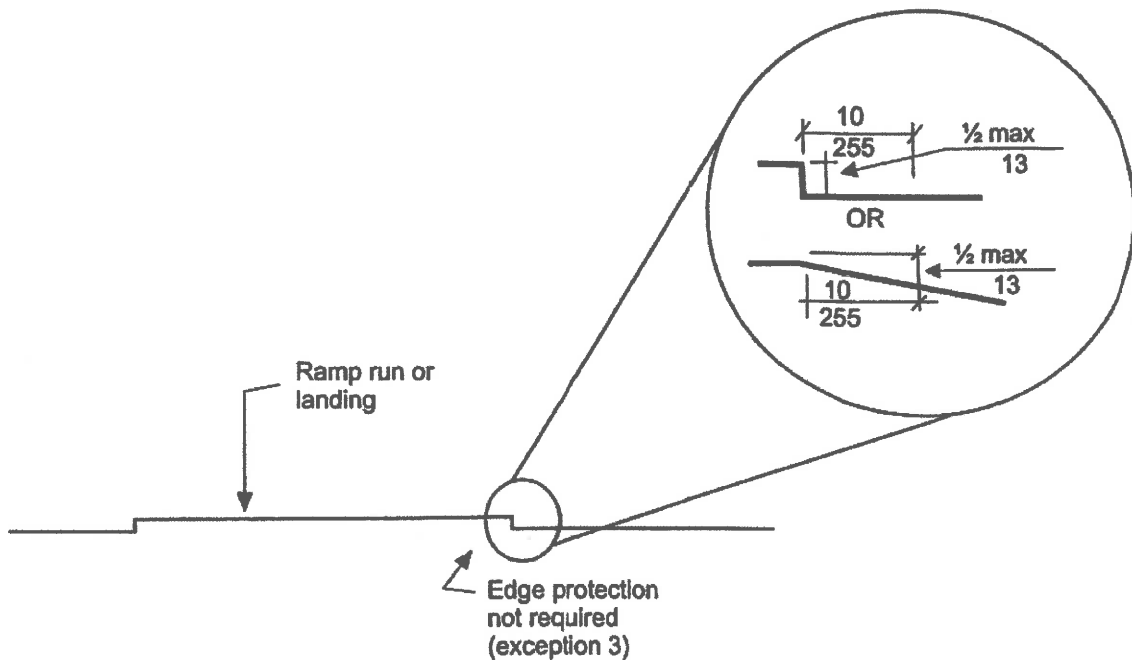

**FIG. 405.9
EDGE PROTECTION—LIMITED DROP OFF**

302 Floor Surfaces

302.1 General. Floor surfaces shall be stable, firm, and slip resistant, and shall comply with Section 302. Changes in level in floor surfaces shall comply with Section 303.

302.2 Carpet. Carpet or carpet tile shall be securely attached and shall have a firm cushion, pad, or backing or no cushion or pad. Carpet or carpet tile shall have a level loop, textured loop, level cut pile, or level cut/uncut pile texture. The pile shall be $\frac{1}{2}$ inch (13 mm) maximum in height. Exposed edges of carpet shall be fastened to the floor and shall have trim along the entire length of the exposed edge. Carpet edge trim shall comply with Section 303.

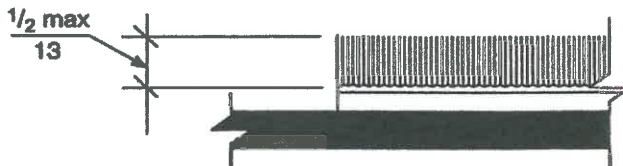

FIG. 302.2
CARPET ON FLOOR SURFACES

302.3 Openings. Openings in floor surfaces shall be of a size that does not permit the passage of a $\frac{1}{2}$ inch (13 mm) diameter sphere, except as allowed in Sections 407.4.3, 408.4.3, 409.4.3, 410.4, and 805.10. Elongated openings shall be placed so that the long dimension is perpendicular to the predominant direction of travel.

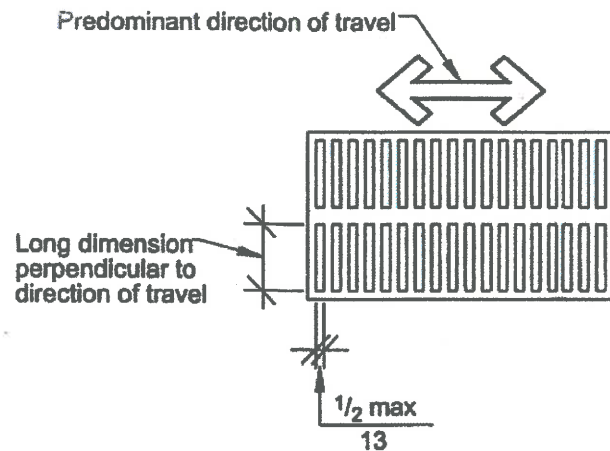

FIG. 302.3
OPENINGS IN FLOOR SURFACES

304 Turning Space

304.1 General. A turning space shall comply with Section 304.

304.2 Floor Surface. Floor surfaces of a turning space shall comply with Section 302. Changes in level are not permitted within the turning space.

EXCEPTION: Slopes not steeper than 1:48 shall be permitted.

304.3 Size. Turning spaces shall comply with Section 304.3.1 or 304.3.2.

304.3.1 Circular Space. The turning space shall be a circular space with a 60-inch (1525 mm) minimum diameter. The turning space shall be permitted to include knee and toe clearance complying with Section 306.

304.3.2 T-Shaped Space. The turning space shall be a T-shaped space within a 60-inch (1525 mm) minimum square, with arms and base 36 inches (915 mm) minimum in width. Each arm of the T shall be clear of obstructions 12 inches (305 mm) minimum in each direction, and the base shall be clear of obstructions 24 inches (610 mm) minimum. The turning space shall be permitted to include knee and toe clearance complying with Section 306 only at the end of either the base or one arm.

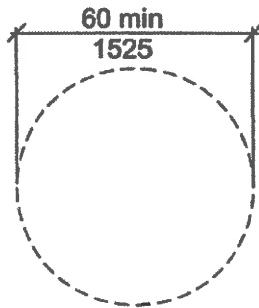

(a) Circular

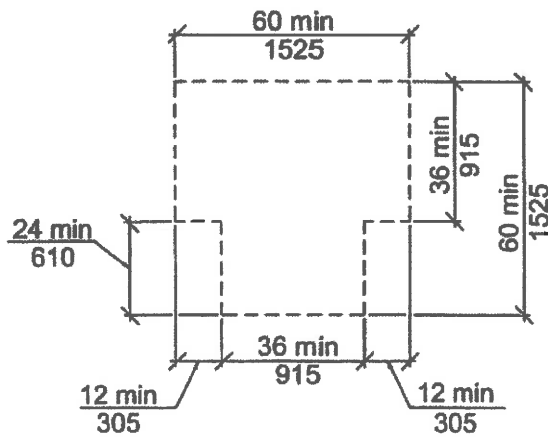

(b) T-shaped

FIG. 304.3
SIZE OF TURNING SPACE

with Section 404.2.3 and shall include the full clear opening width of the doorway. Required door maneuvering clearances shall not include knee and toe clearance.

404.2.3.1 Floor Surface. Floor surface within the maneuvering clearances shall have a slope not steeper than 1:48 and shall comply with Section 302.

404.2.3.2 Swinging Doors. Swinging doors shall have maneuvering clearances complying with Table 404.2.3.2.

404.2.3.3 Sliding and Folding Doors. Sliding doors and folding doors shall have maneuvering clearances complying with Table 404.2.3.3.

404.2.3 Maneuvering Clearances. Minimum maneuvering clearances at doors shall comply

TABLE 404.2.3.2—MANEUVERING CLEARANCES AT MANUAL SWINGING DOORS

TYPE OF USE		MANEUVERING CLEARANCES AT MANUAL SWINGING DOORS	
Approach Direction	Door Side	Perpendicular to Doorway	Parallel to Doorway (beyond latch unless noted)
From front	Pull	60 inches (1525 mm)	18 inches (455 mm)
From front	Push	48 inches (1220 mm)	0 inches (0 mm) ³
From hinge side	Pull	60 inches (1525 mm)	36 inches (915 mm)
From hinge side	Pull	54 inches (1370 mm)	42 inches (1065 mm)
From hinge side	Push	42 inches (1065 mm) ¹	22 inches (560 mm) ^{3 & 4}
From latch side	Pull	48 inches (1220 mm) ²	24 inches (610 mm)
From latch side	Push	42 inches (1065 mm) ²	24 inches (610 mm)

¹Add 6 inches (150 mm) if closer and latch provided.
²Add 6 inches (150 mm) if closer provided.
³Add 12 inches (305 mm) beyond latch if closer and latch provided.
⁴Beyond hinge side.

TABLE 404.2.3.3—MANEUVERING CLEARANCES AT SLIDING AND FOLDING DOORS

Approach Direction	MINIMUM MANEUVERING CLEARANCES	
	Perpendicular to Doorway	Parallel to Doorway (beyond stop or latch side unless noted)
From front	48 inches (1220 mm)	0 inches (0 mm)
From nonlatch side	42 inches (1065 mm)	22 inches (560 mm) ¹
From latch side	42 inches (1065 mm)	24 inches (610 mm)

¹Beyond pocket or hinge side.

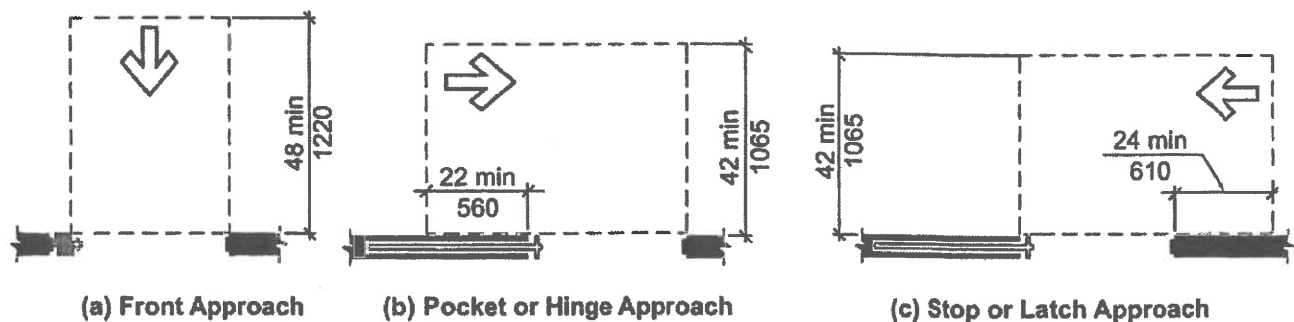

FIG. 404.2.3.3
MANEUVERING CLEARANCE AT SLIDING AND FOLDING DOORS

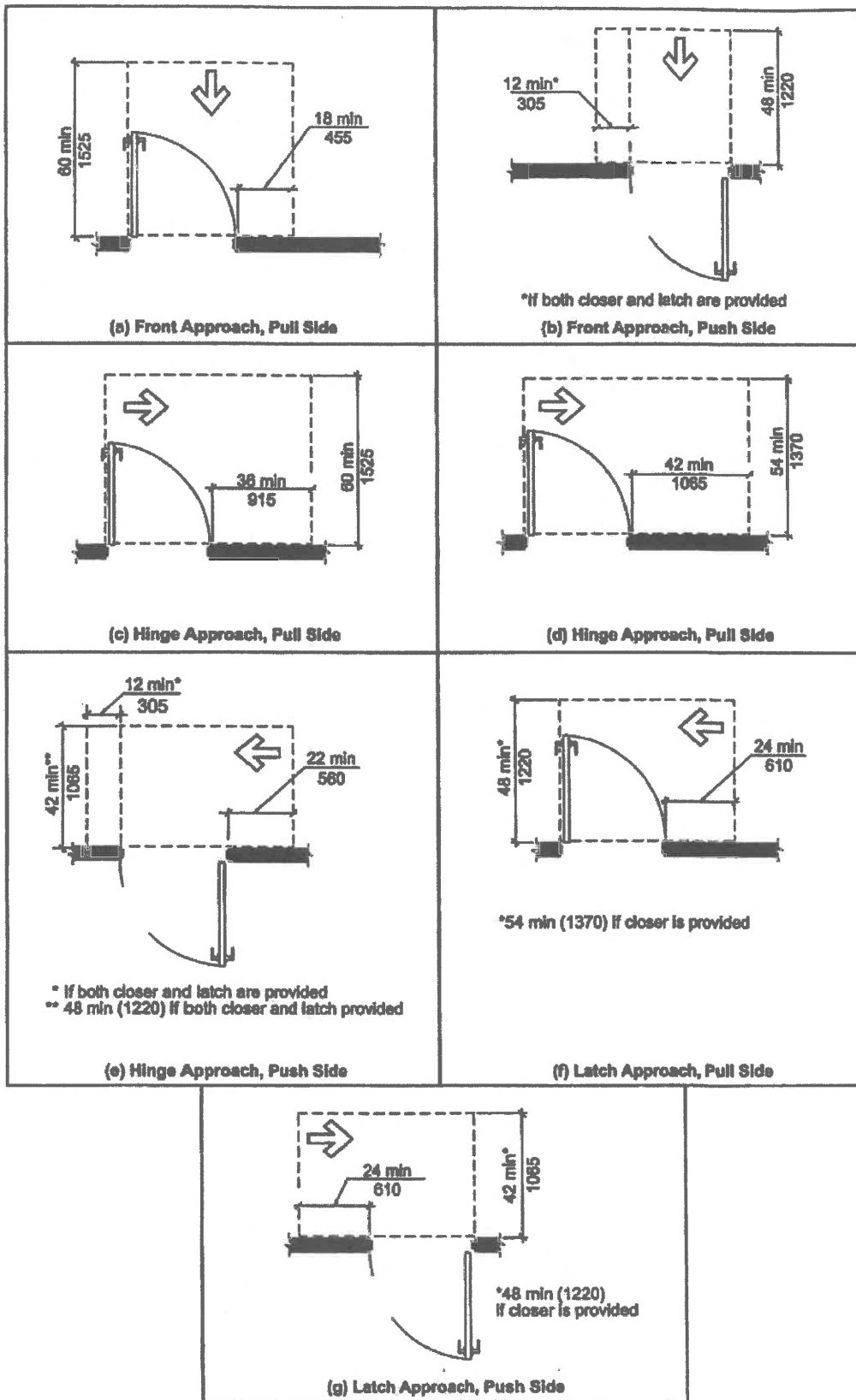

FIG. 404.2.3.2
 MANEUVERING CLEARANCE AT MANUAL SWINGING DOORS

505.1 General. Handrails required by Section 405.8 for ramps, or Section 504.6 for stairs, shall comply with Section 505.

ICC A117.1-2009

505.2 Location. Handrails shall be provided on both sides of stairs and ramps.

EXCEPTIONS:

1. In assembly seating areas, handrails shall not be required on both sides along aisle stairs, provided with a handrail either at the side or within the aisle.
2. In assembly seating areas, handrails shall not be required on the sides of ramped aisles serving seats.

505.3 Continuity. Handrails shall be continuous within the full length of each stair flight or ramp run. Inside handrails on switchback or dogleg stairs or ramps shall be continuous between flights or runs. Other handrails shall comply with Sections 505.10 and 307.

EXCEPTION: Handrails shall not be required to be continuous in aisles serving seating where handrails are discontinuous to provide access to seating and to permit crossovers within the aisles.

505.4 Height. Top of gripping surfaces of handrails shall be 34 inches (865 mm) minimum and 38 inches (965 mm) maximum vertically above stair nosings, ramp surfaces and walking surfaces. Handrails shall be at a consistent height above stair nosings, ramp surfaces and walking surfaces.

505.5 Clearance. Clearance between handrail gripping surface and adjacent surfaces shall be 1½ inches (38 mm) minimum.

505.6 Gripping Surface. Gripping surfaces shall be continuous, without interruption by newel posts, other construction elements, or obstructions.

EXCEPTIONS:

1. Handrail brackets or balusters attached to the bottom surface of the handrail shall not be considered obstructions, provided the brackets or balusters comply with the following criteria:
 - a. Not more than 20 percent of the handrail length is obstructed,

- b. Horizontal projections beyond the sides of the handrail occur 1½ inches (38 mm) minimum below the bottom of the handrail, and provided that for each ½ inch (13 mm) of additional handrail perimeter dimension above 4 inches (100 mm), the vertical clearance dimension of 1½ inch (38 mm) can be reduced by ⅛ inch (3.2 mm), and
- c. Edges shall be rounded.

2. Where handrails are provided along walking surfaces with slopes not steeper than 1:20, the bottoms of handrail gripping surfaces shall be permitted to be obstructed along their entire length where they are integral to crash rails or bumper guards.

505.7 Cross Section. Handrails shall have a cross section complying with Section 505.7.1 or 505.7.2.

505.7.1 Circular Cross Section. Handrails with a circular cross section shall have an outside diameter of 1¼ inches (32 mm) minimum and 2 inches (51 mm) maximum.

505.7.2 Noncircular Cross Sections. Handrails with a noncircular cross section shall have a perimeter dimension of 4 inches (100 mm) minimum and 6¼ inches (160 mm) maximum, and a cross-section dimension of 2¼ inches (57 mm) maximum.

505.8 Surfaces. Handrails, and any wall or other surfaces adjacent to them, shall be free of any sharp or abrasive elements. Edges shall be rounded.

505.9 Fittings. Handrails shall not rotate within their fittings.

505.10 Handrail Extensions. Handrails shall extend beyond and in the same direction of stair flights and ramp runs in accordance with Section 505.10.

EXCEPTIONS:

1. Continuous handrails at the inside turn of stairs and ramps.

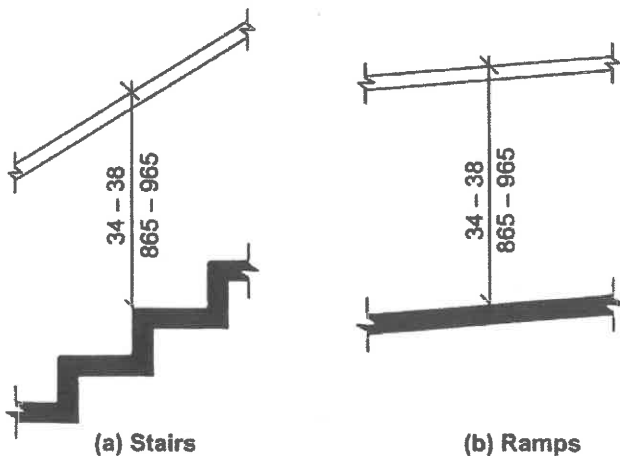

FIG. 505.4
HANDRAIL HEIGHT

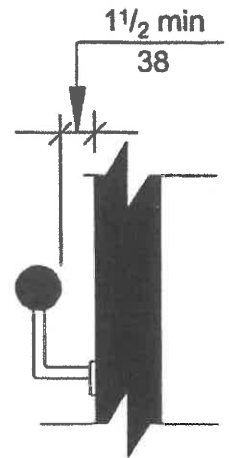

FIG. 505.5
HANDRAIL CLEARANCE

2. Handrail extensions are not required in aisles serving seating where the handrails are discontinuous to provide access to seating and to permit crossovers within the aisle.
3. In alterations, full extensions of handrails shall not be required where such extensions would be hazardous due to plan configuration.

505.10.1 Top and Bottom Extension at Ramps. Ramp handrails shall extend horizontally above the landing 12 inches (305 mm) minimum beyond the top and bottom of ramp runs. Extensions shall return to a wall, guard, or floor, or shall be continuous to the handrail of an adjacent ramp run.

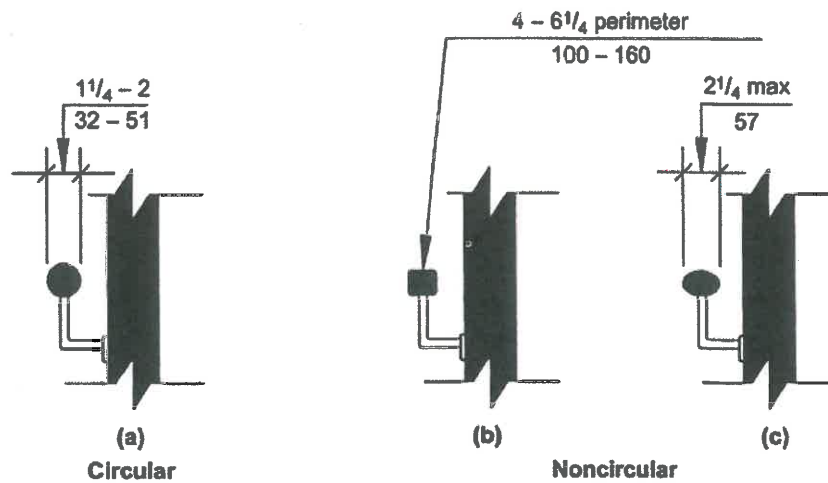

FIG. 505.7
HANDRAIL CROSS SECTION

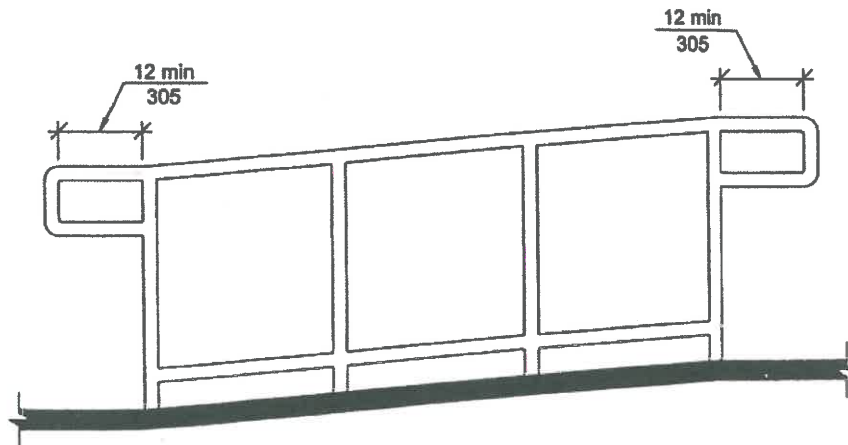

FIG. 505.10.1
TOP AND BOTTOM HANDRAIL EXTENSIONS AT RAMPS